

TONNOS Power Tonneau Kit



INSTALLATION

1. Assemble Snap-In Tonneau Kit. Provided brackets need to be bolted to each end of linear actuator (see image.)
2. Open tonneau cover.
3. Locate existing gas strut and measure mounting points for extended and compressed lengths. Compressed length needs to be more 13.5 inches for the linear actuator to fit properly. Linear actuators maximum length is 21.5 inches.
4. If your brackets are not within these specifications, they may need to be moved. All vehicle applications vary so measure twice. Check for clearance.
5. Remove pins in Snap-In Tonneau Kit brackets and snap into upper and lower ball joints. **Included are new 2 ball joints if your tonneau cover has different mounting methods.*
6. Insert pins back into brackets and lock into place.
7. Follow wiring diagram below.
8. Mount button in truck cab.

WIRING DIAGRAM

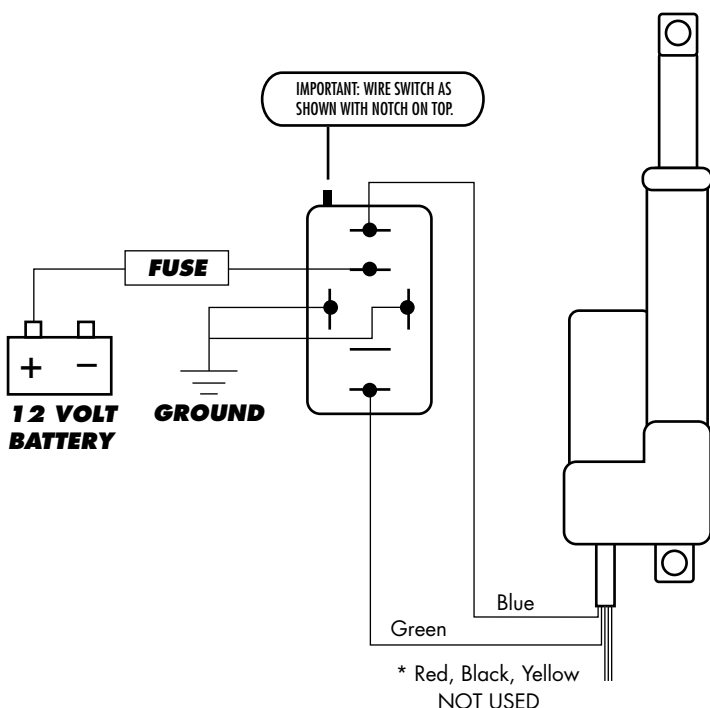

FINAL INSTALLATION

