



# Installation Instruction Manual



**STEP 1**

Attach brackets in front corners with 2 self tapping screws. Make Sure the brackets are mounted flush with the top edge of your truck bed rail.

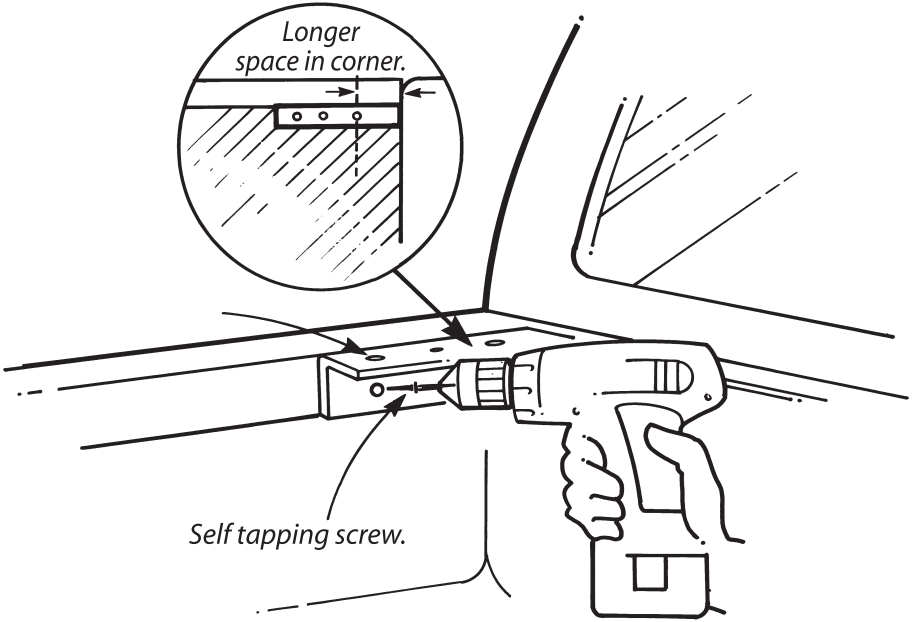

Some trucks inner rails are not straight. In this instance, use the provided shims to offset the inner rail contours or shapes. (See diagram #2 as an example)

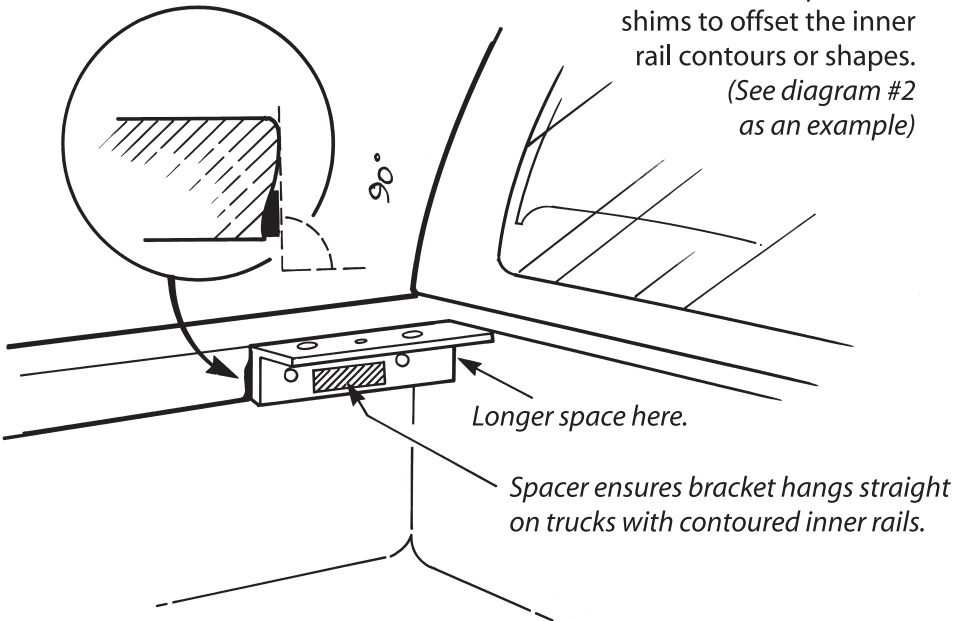

## STEP 2

Hang canister on mounded brackets. Fasten permanently in place using 1 self tapping screw in center of bracket on each side.

Make sure the holes in the canister brackets match the holes on the hanger brackets.

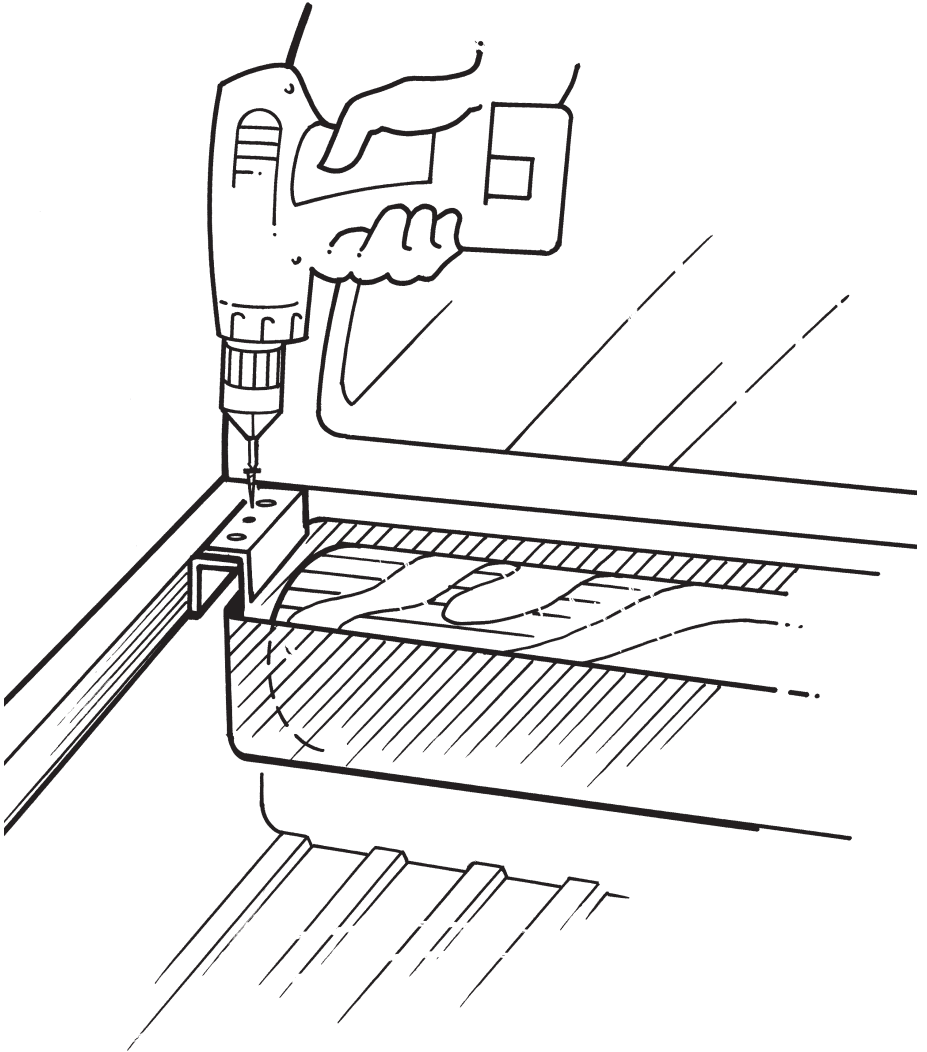

### STEP 3

Attach rails to truck bed using clamps. Rails should be flush with the closed tailgate. Position 3 clamps on each side per diagram. Shim rails if necessary, in order to ensure that your rails are not tilted at an angle.

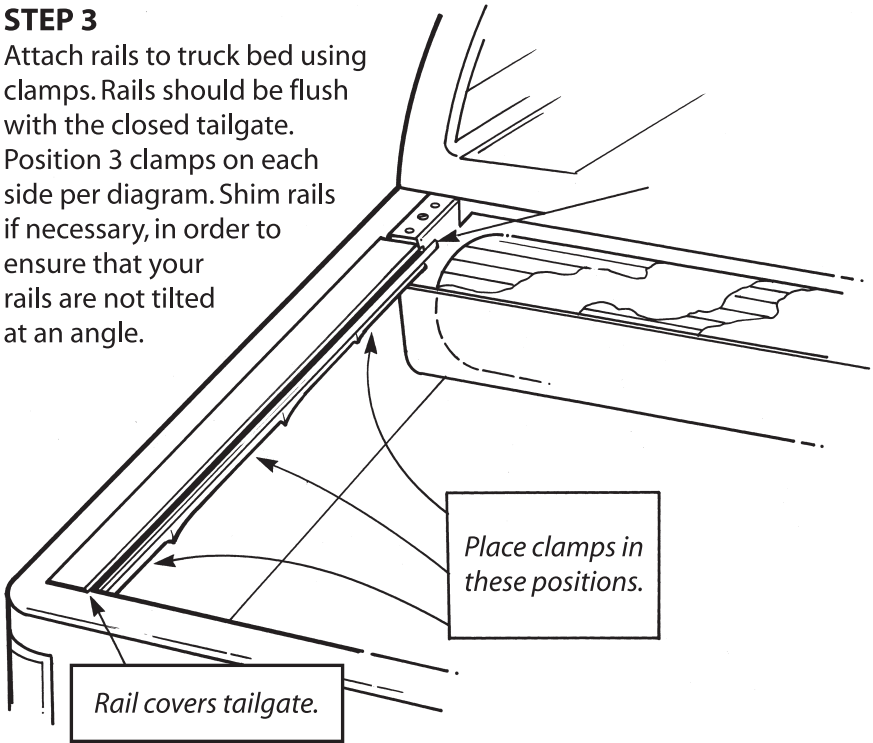

#### **CHEVY TRUCKS:**

Require shims at the bottom edge of inner rail.

#### **97-03 F-150 TRUCKS:**

Require shims at top edge of inner rails.

#### **DODGE RAM TRUCKS:**

Please refer to attached guide.

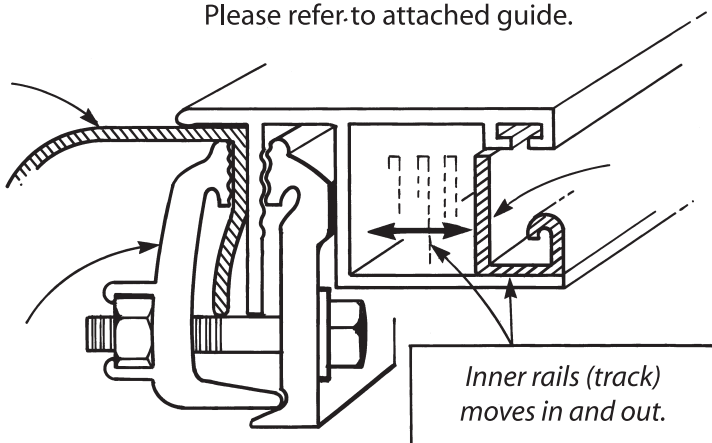

## STEP 4

Once rails are clamped on, grease the top edge of the inner tracks. Now slide the inner tracks to their narrowest (innermost) position. The inner track should be as close to the center of the truck bed as possible. Now hand tighten the nut under the rail, just behind the canister.

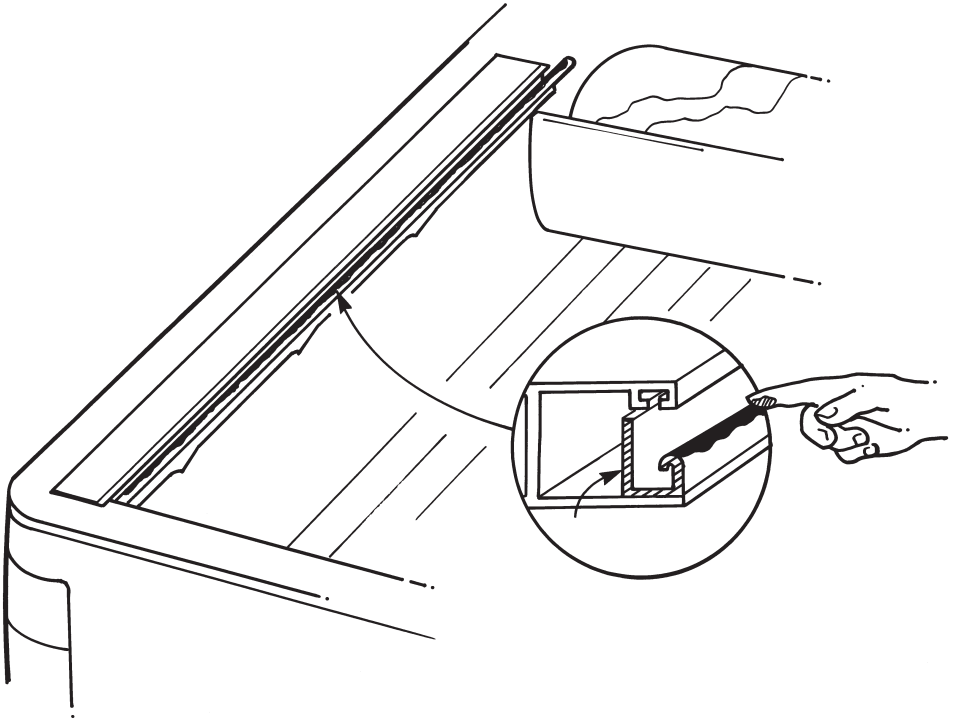

## **STEP 5**

Wind canister clockwise (*toward the tailgate*), until it wont wind anymore.  
(*approx. 12 times*)

Then unwind the canister:

4 times for short bed trucks.

7 times for 8' (*long bed trucks*).

**DO NOT REMOVE PLASTIC SHRINK WRAP.**

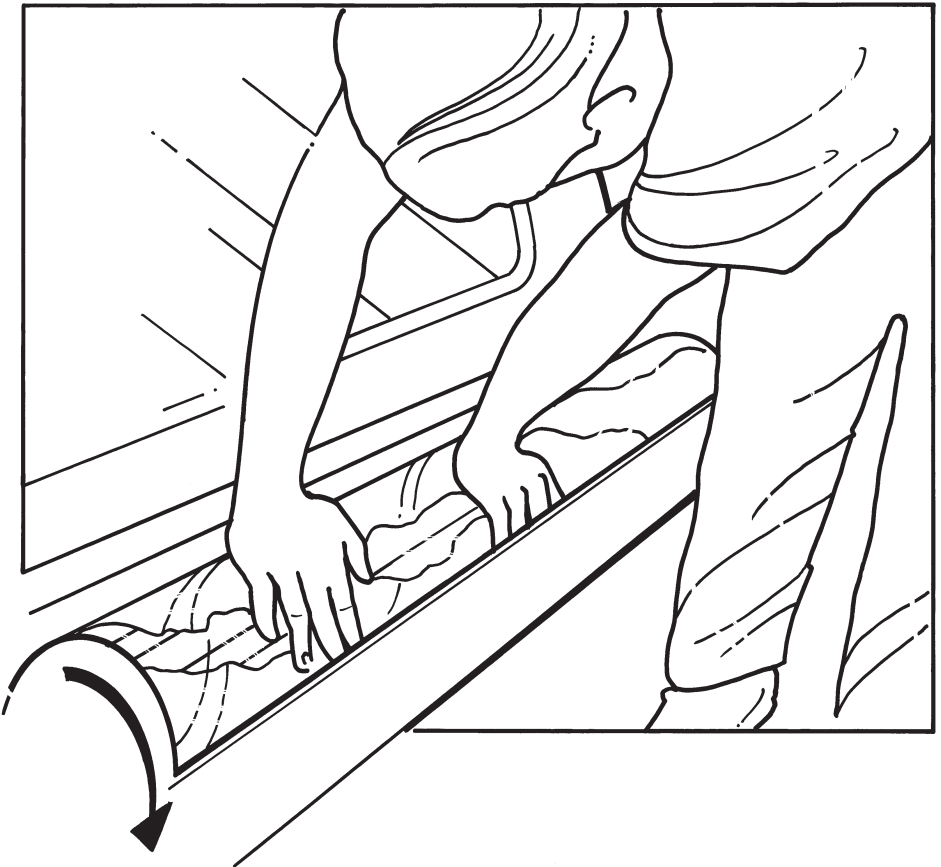

## STEP 6

Once the spring is set, per step 5, remove shrink wrap by hand, making sure the cover does not unwind.

Then slide the handle onto the last slat of the cover as per the diagram.



## STEP 7

Once the handle is on, feed the cover into the tracks. Then hand tighten the nut under the rail so that the inner track at the front doesn't move.

You may need someone to hold the strap of the handle while you do this.

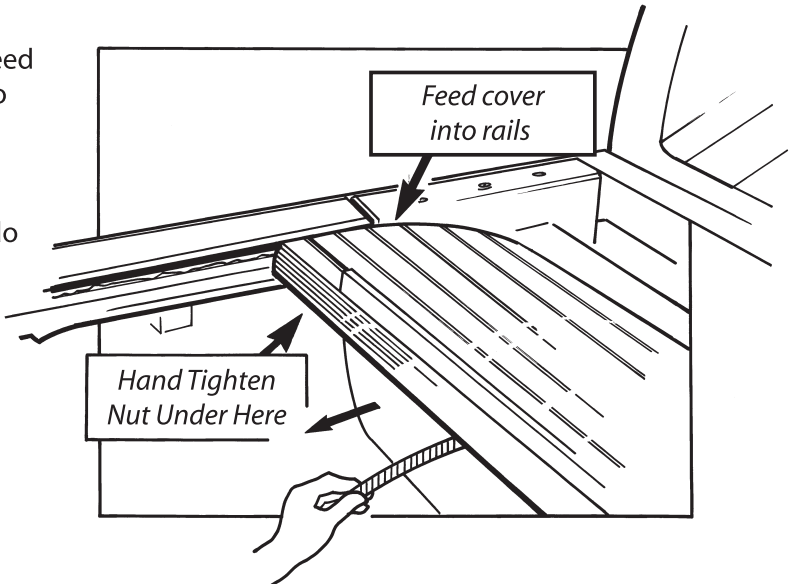

## STEP 8

Set lock behind pin (to open position) Pull the cover all the way closed. Doing this will set your inner track on which the cover rolls.

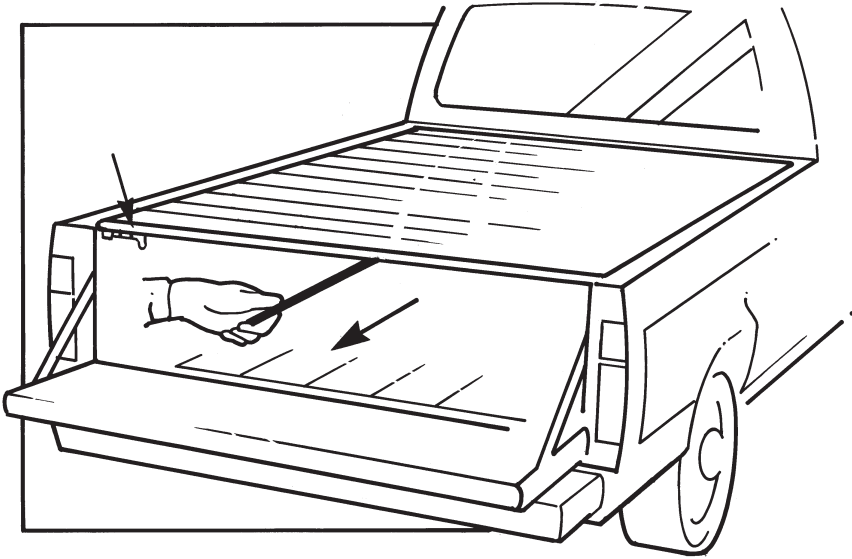

Make sure the cover hooks behind the safety catch on the passenger side rail at the tailgate end.

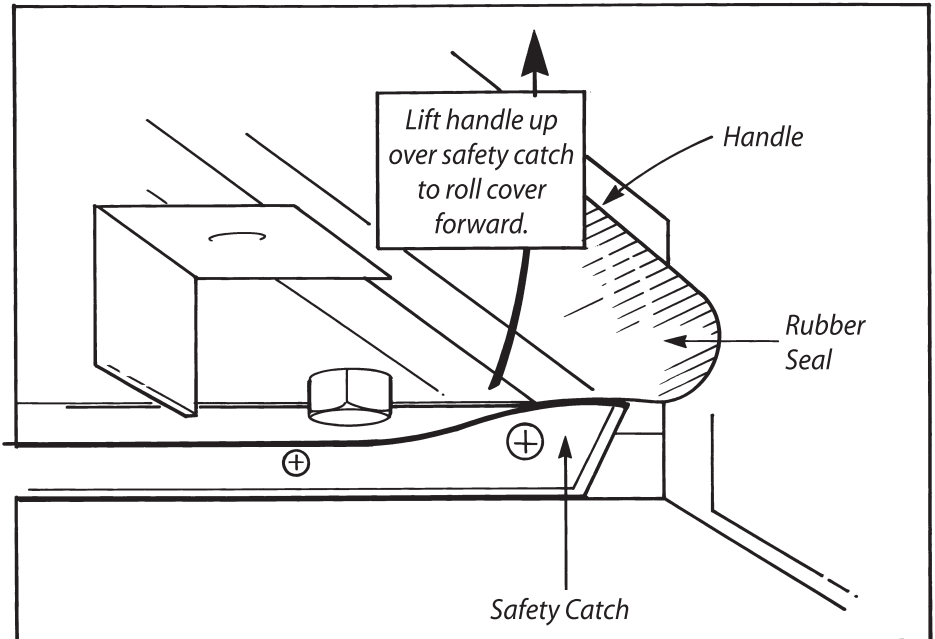

## STEP 9

While pulling the cover as tightly closed as possible, release the lock pin. Then set the sliding lock bar (under the drivers side rail) by positioning it tightly against the closed lock pin. Then tighten the bolts at the rear (under the side rails) on the driver and passenger side rails.

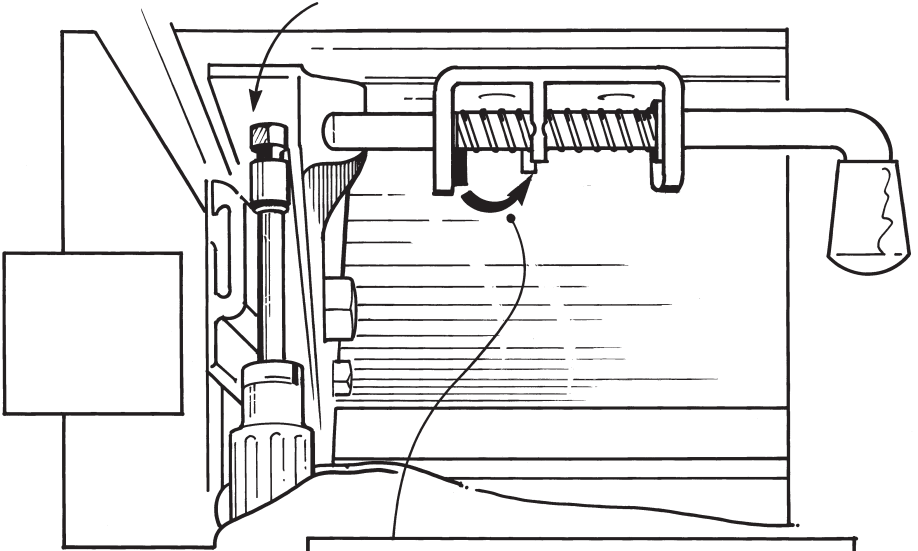

*Set pin on lock behind the rear vertical pin to roll cover forward.*

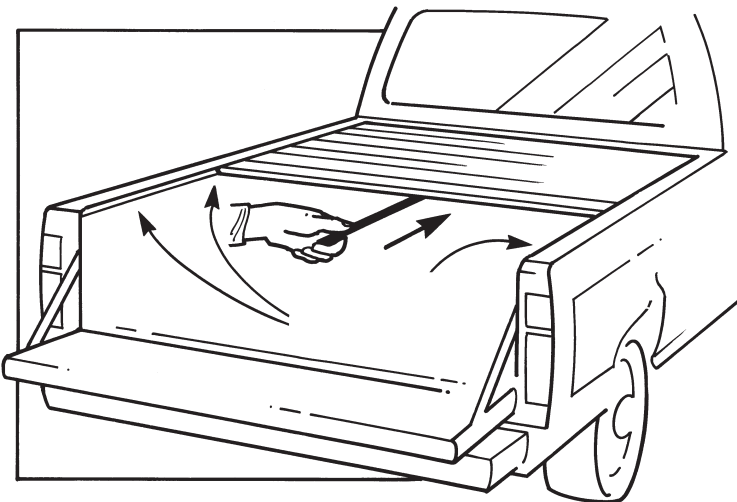

## STEP 10

Allow cover to slide forward in increments, tightening bolts under the rail on the both sides.

## STEP 11

While someone holds the strap, preventing the cover from rolling forward, Attach the bracing bar behind the canister as shown.

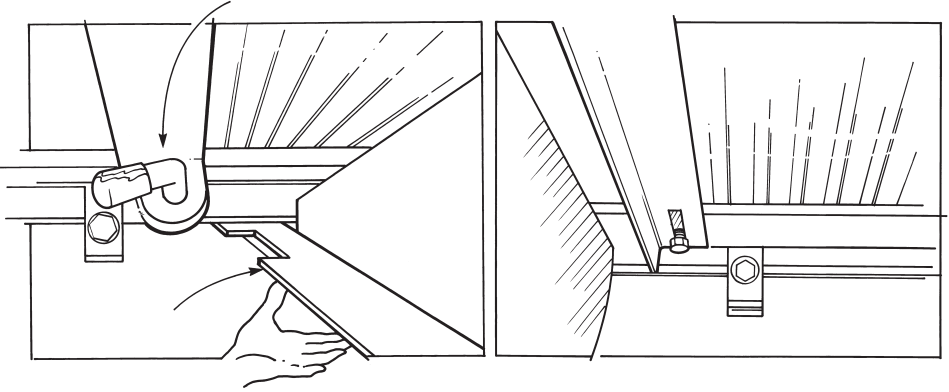

When lock is set and your cover is lifted off the safety catch (see step 8) - the cover will roll forward.

The lock will hit the striker plate (on the bracing bar) and then engage itself.

When you pull the cover toward you (closed), the lock will ratchet behind the notches on the lock bar under the drivers side rail.

This is how you are able to use the cover in intermittent positions.

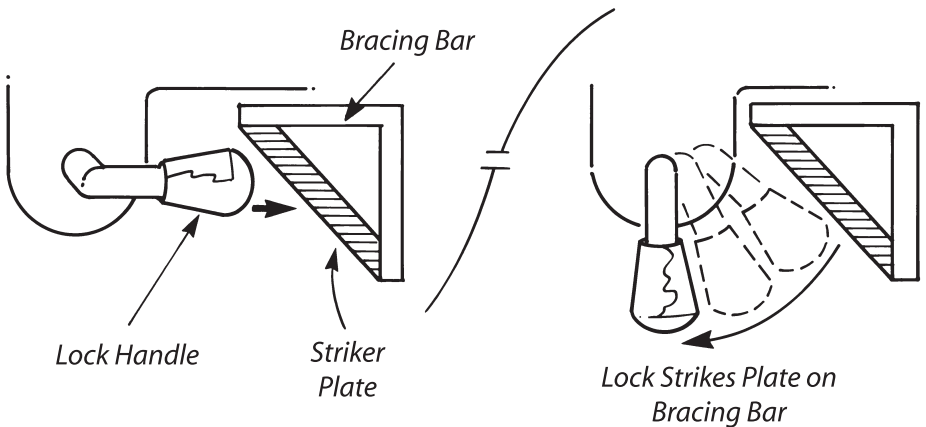

**STEP 12**

Attach lid with provided screws.

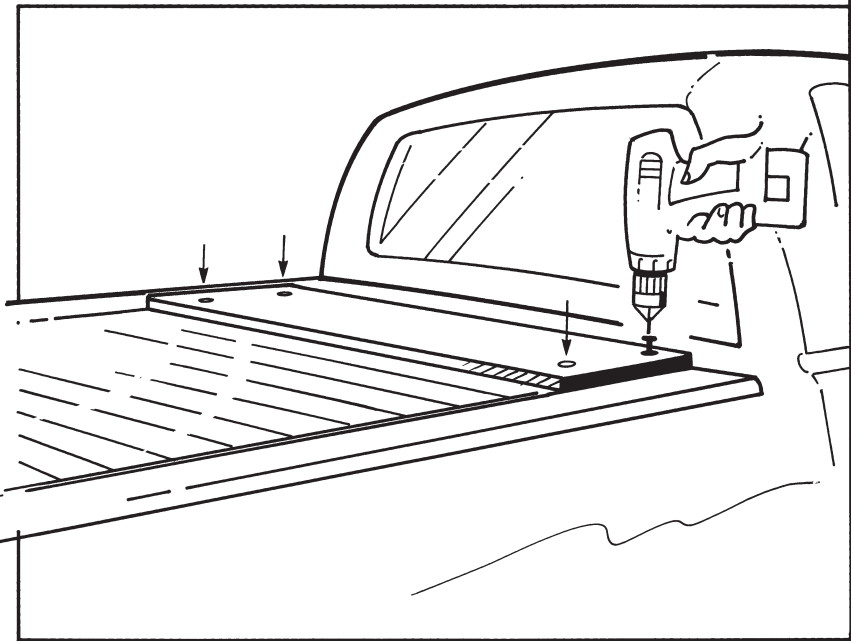

**STEP 13**

Attach drain hoses and run out bottom of truck bed.

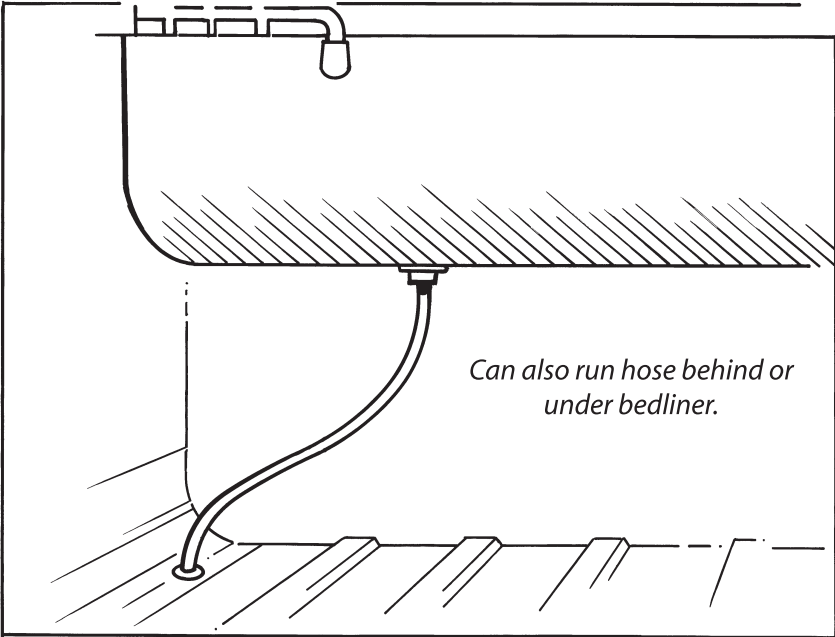

**BAK INDUSTRIES**

*7307 Coldwater Canyon Ave.*

*North Hollywood, CA 91605 U.S.A.*

*Phone: (818) 764-0031 Fax: (818) 764-4750*

*E-mail: [info@bakliner.com](mailto:info@bakliner.com)*